

A STUDY ON GRID FORMING INVERTERS

Sakshi Rajendra Thorat¹, Dr. P. V. Paratwar²

^{1,2} *Department of Electrical Engineering, Dattakala College of Engineering, Savitribai Phule
Pune University (SPPU) Pune, India.*

Email: sakshithorat0440@gmail.com¹, pparatwar.foe@dattakala.edu.in²

Abstract

Grid-forming inverters (GFMs) are emerging as a key technology for renewable-energy-dominated power systems due to their capability to provide voltage and frequency support, virtual inertia, and stable operation under weak grid conditions. This paper presents a comparative study of major grid-forming inverter methodologies based on three recent review papers. The work compares droop control, virtual synchronous generator (VSG), power synchronization control (PSC), synchronverter, and virtual oscillator control (VOC) methods in terms of control structure, synchronization capability, transient stability, fault ride-through capability, and applications. The comparative analysis shows that VSG and PSC methods provide superior grid-support capabilities, while droop control offers simplicity and easy implementation. VOC-based techniques provide enhanced synchronization dynamics for future converter-dominated grids. The study concludes that hybrid control strategies integrating virtual inertia and adaptive current-limiting methods are promising solutions for future low-inertia power systems.

Keywords: Grid-forming Inverter, Virtual Synchronous Generator, Droop Control, Power Synchronization Control, Renewable Energy Integration, Weak Grid Stability.

► *Corresponding Author: Sakshi Rajendra Thorat*

1. Introduction

The increasing penetration of renewable energy sources such as solar photovoltaic and wind energy has transformed modern electrical power systems into converter-dominated networks. Traditional synchronous generators inherently provide inertia, voltage support, and fault current capability. However, conventional grid-following (GFL) inverters depend on phase-locked loops (PLLs) and cannot independently regulate system voltage or frequency.

To overcome these limitations, grid-forming inverter (GFM) technology has been developed. GFM converters behave as controlled voltage sources and can establish voltage and frequency references autonomously. These converters improve system stability, support weak grids, and enable black-start operation.

Recent studies have proposed multiple GFM control methodologies including:

- Droop control
- Virtual synchronous generator (VSG)
- Power synchronization control (PSC)
- Synchronverter control
- Virtual oscillator control (VOC)

This paper presents a comparative review of these methodologies using the three provided research papers:

- Grid Forming Converters in Renewable Energy Sources Dominated Power Grid
- Grid Forming Inverter Modeling, Control, and Applications
- Grid-Forming Converters: Control Approaches, Grid-Synchronization, and Future Trends

2. Need for Grid-Forming Inverters

Conventional GFL inverters suffer from several disadvantages:

- Poor weak-grid stability
- Lack of inertia support
- Dependence on PLL synchronization
- Inability to operate in islanded mode
- Limited fault current support

The comparison between GFL and GFM converters shows that GFM converters operate as voltage sources behind impedance and can self-synchronize without relying on PLLs.

3. Grid-Forming Control Methodologies

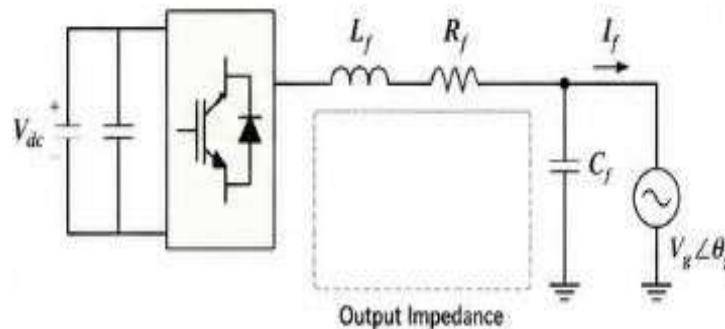

Fig 1. Single phase equivalent circuit of a grid forming inverter

3.1 Droop Control

Droop control is one of the earliest and most widely used GFM techniques. It emulates the governor action of synchronous generators by adjusting frequency according to active power variations.

The active power–frequency relationship is: $\omega = \omega_{ref} + D_f (P^* - P)$

where:

- D_f = droop coefficient
- P^* = reference power
- P = measured power

Droop control is one of the earliest and most widely used grid-forming control methods. The technique allows multiple converters to share power effectively while maintaining stable operation. Due to its decentralized structure and simple implementation, droop control is commonly used in microgrids and distributed renewable-energy systems.

The method adjusts inverter operation according to active and reactive power variations and provides coordinated operation among parallel-connected converters.

3.2 Virtual Synchronous Generator (VSG)

The VSG method emulates the electromechanical behavior of synchronous machines using virtual inertia and damping loops.

The swing equation used in VSG control is:

$$J \frac{d\omega}{dt} = T_m - T_e - D_p (\omega - \omega_0)$$

where:

- J = virtual inertia
- D_p = damping coefficient
- T_m = mechanical torque
- T_e = electrical torque

Virtual synchronous generator control imitates the operational behavior of conventional synchronous generators. The control strategy introduces virtual inertia and damping characteristics into the inverter system to improve stability and frequency regulation.

VSG control improves system response during disturbances and supports stable operation under weak-grid conditions. This method is considered highly suitable for renewable-energy-dominated power systems because it reproduces important characteristics of synchronous machines.

3.3 Power Synchronization Control (PSC)

PSC achieves synchronization through active power dynamics instead of PLL mechanisms. It is particularly effective for weak-grid operation.

The control equation is:

$$\vartheta = \frac{1}{s} [k_i(P^* - P)] + \vartheta_{ref}$$

Power synchronization control achieves synchronization through power dynamics instead of conventional phase-locked loop structures. PSC improves weak-grid synchronization capability and provides better transient stability compared to traditional grid-following methods.

The method is highly effective in converter-dominated systems where synchronization reliability is important for stable operation.

3.4 Synchronverter Control

Synchronverter control fully emulates synchronous machine behavior, including inertia and damping characteristics.

Synchronverter control closely reproduces the operational characteristics of synchronous generators including damping behavior, synchronization capability, and voltage regulation.

The method improves system dynamic response and provides stable operation during sudden disturbances and load variations. Synchronverter-based systems are increasingly studied for modern renewable-energy integration.

3.5 Virtual Oscillator Control (VOC)

VOC uses nonlinear oscillator dynamics to achieve synchronization without communication or PLL structures.

Virtual oscillator control uses nonlinear oscillator principles to achieve synchronization without depending on communication systems or phase-locked loop structures.

The method provides rapid synchronization capability and improved dynamic response for future decentralized smart-grid systems. VOC is considered a promising technology for advanced converter-dominated power networks.

4. Comparative Analysis of Methodologies

Different grid-forming inverter control methods have unique characteristics and performance advantages. Droop control is simple, reliable, and widely used in microgrids, but it provides limited inertia support and slower dynamic response. Virtual Synchronous Generator (VSG) control offers better frequency stability and virtual inertia support, making it highly suitable for weak-grid applications, although its control structure is more complex.

Power Synchronization Control (PSC) provides excellent synchronization capability and improved stability under weak-grid conditions without depending on phase-locked loops. Synchronverter control closely imitates synchronous generator behavior and provides smooth transient response and strong grid support capability.

Virtual Oscillator Control (VOC) offers very fast synchronization and strong dynamic performance, making it promising for future smart-grid applications.

Among all methods, VSG and PSC are considered more effective for renewable-energy-dominated power systems because of their superior stability and grid-support features, while droop control remains popular due to its simplicity and practical implementation.

The comparative study indicates that:

- VSG and synchronverter methods are best for inertia emulation.
- PSC is highly suitable for weak-grid synchronization.
- Droop control remains practical for microgrids due to simplicity.
- VOC is promising for future autonomous grid operation.

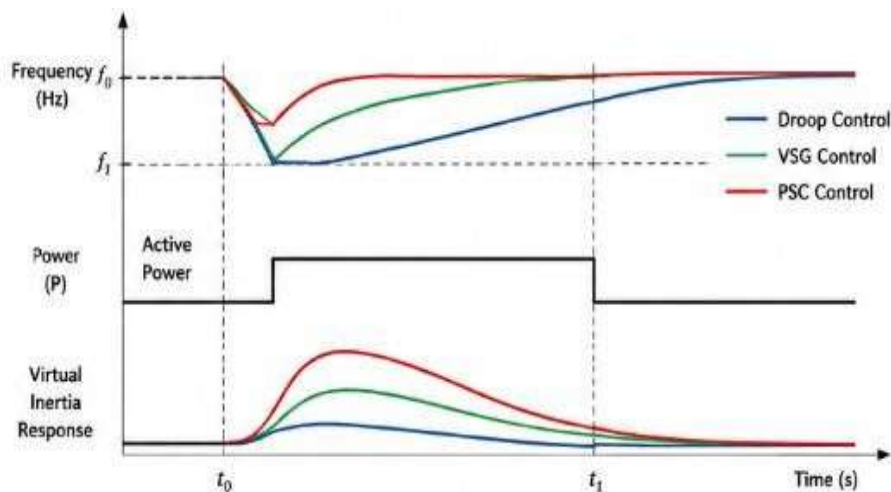

Fig 2. Frequency response comparison

5. Challenges in Grid-Forming Inverters

Despite their advantages, GFM converters face several technical challenges:

- Fault current limitation
- Transient instability

- Parameter tuning
- Energy storage coordination
- Protection coordination

The reviewed papers emphasize that current-limiting strategies can negatively impact transient stability during faults.

6. Applications of Grid-Forming Inverters

Major applications include:

- Renewable energy integration
- Offshore wind farms
- HVDC systems
- Islanded microgrids
- Battery energy storage systems
- Electric vehicle charging stations

GFM is increasingly being adopted in weak-grid regions to improve system strength and reliability.

7. Conclusion

Grid-forming inverter technology represents a major advancement for future renewable-dominated power systems. Unlike conventional grid-following converters, GFM converters can autonomously regulate voltage and frequency while supporting system stability.

The comparative analysis shows that:

- Droop control provides simplicity and reliable power sharing.
- VSG and synchronverter methods provide excellent inertia support.
- PSC offers superior weak-grid synchronization.
- VOC introduces advanced self-synchronization capability for future smart grids.

Future research should focus on adaptive control techniques, advanced protection systems, and hybrid GFM architectures to improve stability and fault ride-through capability in converter-dominated power systems.

References

1. Haobo Zhang et al., —Grid Forming Converters in Renewable Energy Sources Dominated Power Grid,|| Journal of Modern Power Systems and Clean Energy, 2021.
2. Dayan B. Rathnayake et al., —Grid Forming Inverter Modeling, Control, and Applications,|| IEEE Access, 2021.
3. Roberto Rosso et al., —Grid-Forming Converters: Control Approaches, Grid-Synchronization, and Future Trends,|| IEEE Open Journal of Industry Applications, 2021.
4. J. Driesen and K. Visscher, —Virtual synchronous generators,|| in 2008 IEEE Power and Energy Society General Meeting - Conversion and Delivery of Electrical Energy in the 21st Century, Pittsburgh, USA, 2008, pp. 1–3.
5. Q.-C. Zhong and G. Weiss, —Synchronverters: Inverters that mimic synchronous generators,|| IEEE Transactions on Industrial Electronics, vol. 58, no. 4, pp. 1259–1267, Apr. 2011.
6. Q.-C. Zhong and T. Hornik, Control of Power Inverters in Renewable Energy and Smart Grid Integration. Hoboken, NJ, USA: Wiley-IEEE Press, 2013.
7. U. Markovic, O. Stanojev, E. Vrettos, P. Aristidou, and G. Hug, —Understanding small-signal stability of low-inertia systems,|| IEEE Transactions on Power Systems, vol. 36, no. 5,

pp. 3997–4017, Sept. 2021.

8. B. Wen, D. Boroyevich, R. Burgos, P. Mattavelli, and Z. Shen, —Analysis of D-Q small-signal impedance of grid-tied inverters,|| IEEE Transactions on Power Electronics, vol. 31, no. 1, pp. 675–687, Jan. 2016.

9. M. Chandorkar, D. Divan, and R. Adapa, —Control of parallel connected inverters in standalone AC supply systems,|| IEEE Transactions on Industry Applications, vol. 29, no. 1, pp. 136–143, Jan./Feb. 1993.

10. S. D’Arco and J. A. Suul, —Virtual synchronous machines — Classification of implementations and analysis of equivalence to droop controllers for microgrids,|| in 2013 IEEE Grenoble Conference, Grenoble, France, 2013, pp. 1–7.